

# DEUTZ E360 Electric System

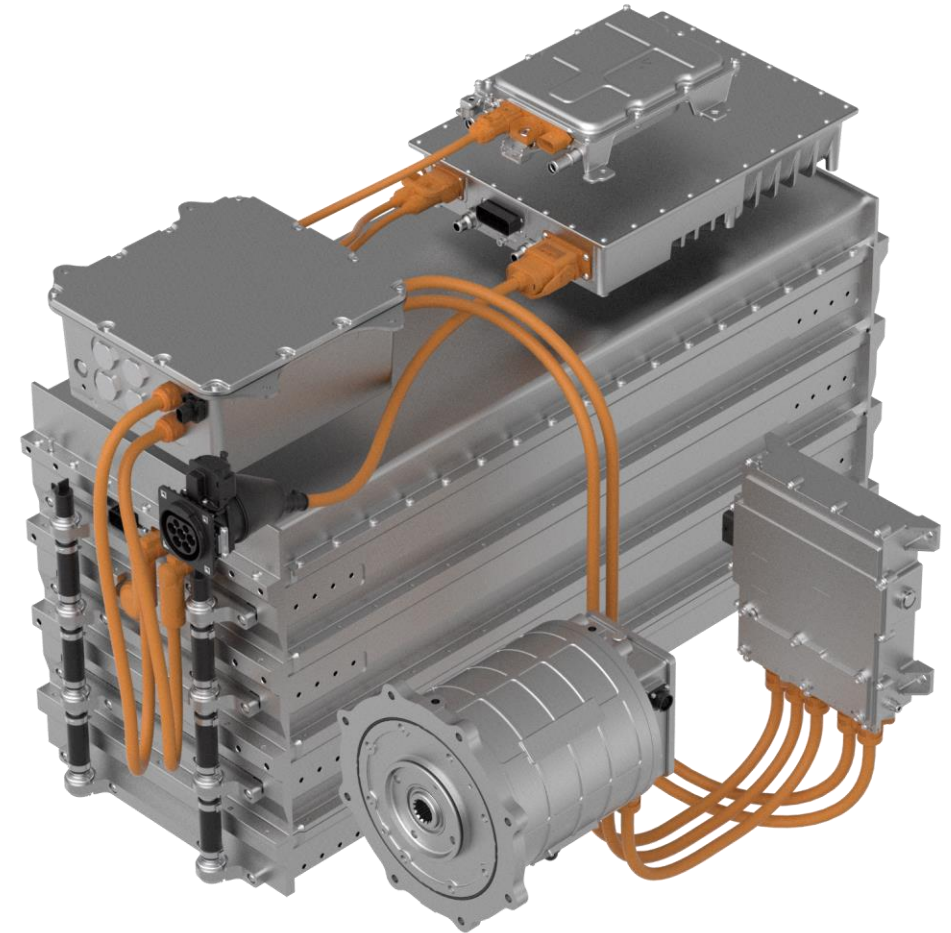

Offers every solution to electrify your vehicle

- **Powerful:** System power up to 120 kW
- **Safe:** High voltage system acc. ISO 26262
- **Robust:** Especially designed for Off-Highway applications
- **Economical:** Low operating costs
- **Compact:** Formfactor for engine compartments or narrow spaces
- **Modular:** Flexible system configurations



# DEUTZ E360 Electric System



## Overview of system's functions & features

### Supply Solutions

- ✓ 12 or 24 V power supply for vehicle
- ✓ Electric power supply for HV-PTOs
  - ✓ Service disconnect
  - ✓ High voltage wiring

### Thermal Solutions

- ✓ Controlled cooling of system components
- ✓ Controlled cooling/heating of batteries
  - ✓ Thermal interface for vehicle
  - ✓ Cabin conditioning

### Control Solutions

- ✓ Control of system & components
  - ✓ VCU communication
  - ✓ SerDia Support
- ✓ Vehicle functions & features

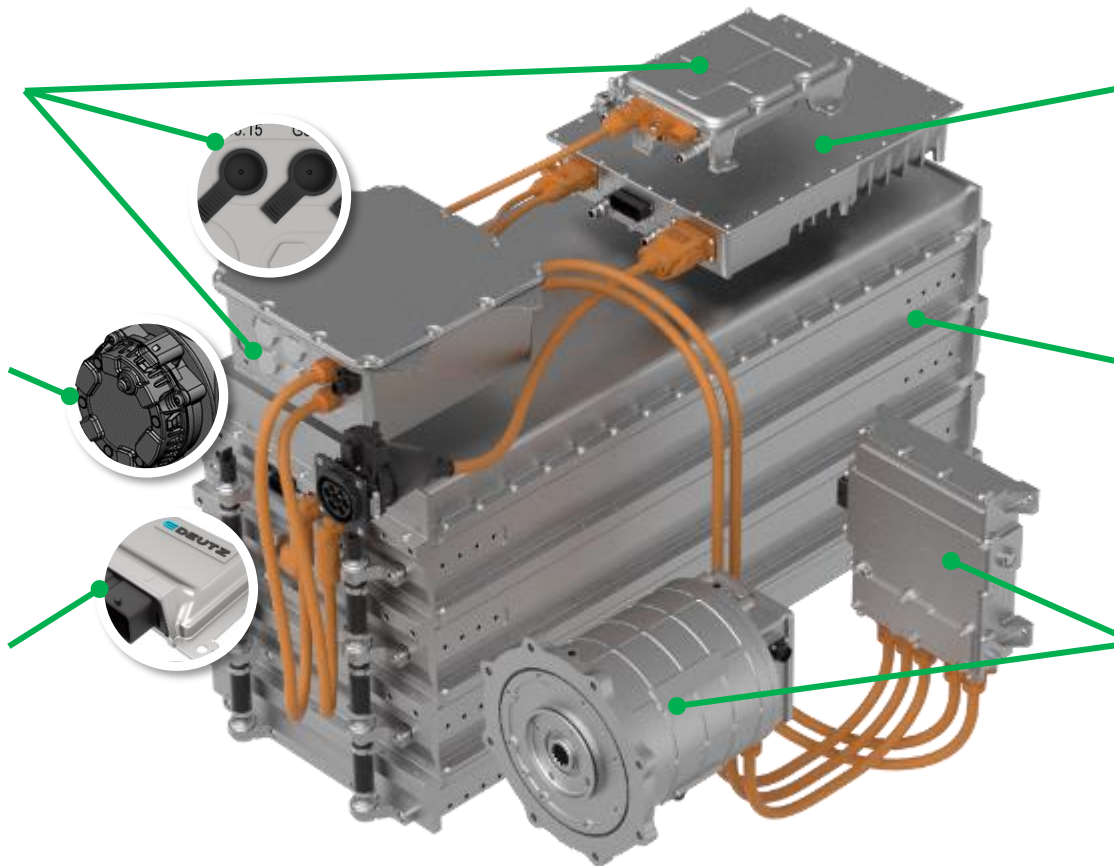

### Charging Solutions

- ✓ Fast charging (AC) up to 22 kW
- ✓ High power charging (DC)
- ✓ Standard charging interfaces for EU & US

### Battery Solutions

- ✓ Capacity and power for your vehicle
- ✓ High power discharging and charging
- ✓ Different variants & combinations available

### Moving Solutions

- ✓ Mechanical output power
- ✓ Regeneration for high efficiency
- ✓ Performance for driving, hydraulics, ...
- ✓ Functional safety acc. to ISO26262

# DEUTZ E360 Electric System



## Configuration

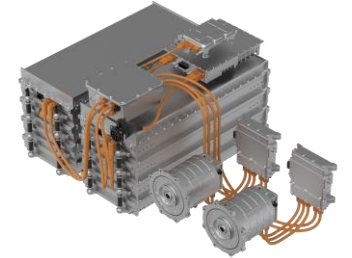
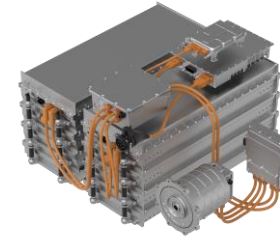
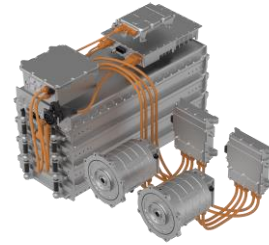
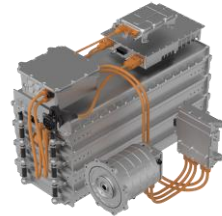

<b>E360 Electric System</b>	Unit	<b>E360 W40-39</b>	<b>E360 W40D40-39</b>	<b>E360 W40-78</b>	<b>E360 W40D40-78</b>
Nominal Capacity	kWh	38.6	38.6	77.2	77.2
Available motoring power	kW	40 kW / 80 kW (30 s)	2x 40 kW / 80 kW (30 s)	40 kW / 80 kW (30 s)	2x 40 kW / 80 kW (30 s)
Discharge Current / Power (nom./max) @ U <sub>nom</sub>	A	176 A / 600 A (10s)	176 A / 600 A (10s)	352 A / 600 A (10s)	352 A / 600 A (10s)
Onboard charging	kW	22 kW			
Ambient Temperature Range	°C	-35 ... +50			
Altitude Range	m	-500 ... +4000			
Humidity	%	0 - 95			
IP protective class	-	IP67, IP6k9k			
Vibration & Shock	-	ISO16750:3 part 9 (30 g)			
Purpose / Application Examples	-	Standard 1:1 substitution Excavator, Airport tow truck	Split drive system Telehandler, Wheel loader	“Long Range” 1:1 Concrete pump, Excavator	“Long Range” Split Municipal
Availability (series)	-	Now	Now	Now	Now