

# DEUTZ G 2.2 / 2.9

Powerful, efficient and compact.



For mobile machinery

The G 2.2 & G 2.9 – With 26 up to 42 kW power output ideal for your application.

- **POWERFUL** / Up to 42 kW & 160 Nm
- **LOW EMISSIONS** / EU Stage V & Tier 2 with 3 - way catalyst
- **MODULAR** / Wide range of applications due to a variety of options
- **VERSATILE** / LPG, CNG (G 2.2) & Gasoline, LPG, Bi - Fuel (G 2.9)



STAGE **V**  
certified

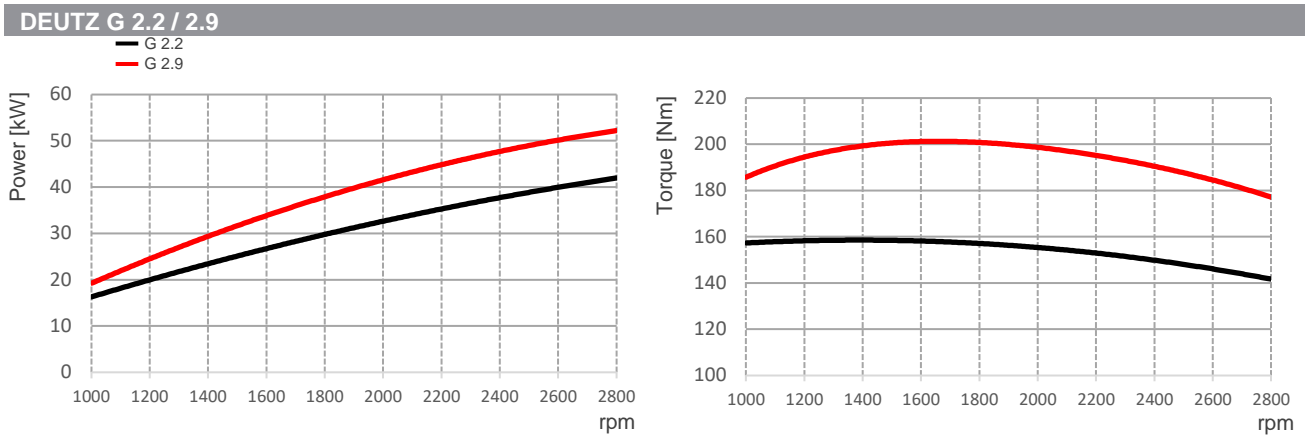

TECHNICAL DATA

ENGINE TYPE	G 2.2	G 2.9
No. of Cylinders	3	4
Displacement	l 2.2	2.9
Max. Nominal Speed	min <sup>-1</sup> 2800	2800
Aspiration	Natural	Natural
Power Output acc. ISO 14396	kW 26 - 41.5	44.1 - 54.5*
At Speed	min <sup>-1</sup> 2800	2800
Max. Torque	Nm 160	209
At Speed	min <sup>-1</sup> 1600	1600
Min. Idling Speed	min <sup>-1</sup> 900	900
Weight (DIN 70020 Part 7A)	kg 208	-

DIMENSIONS

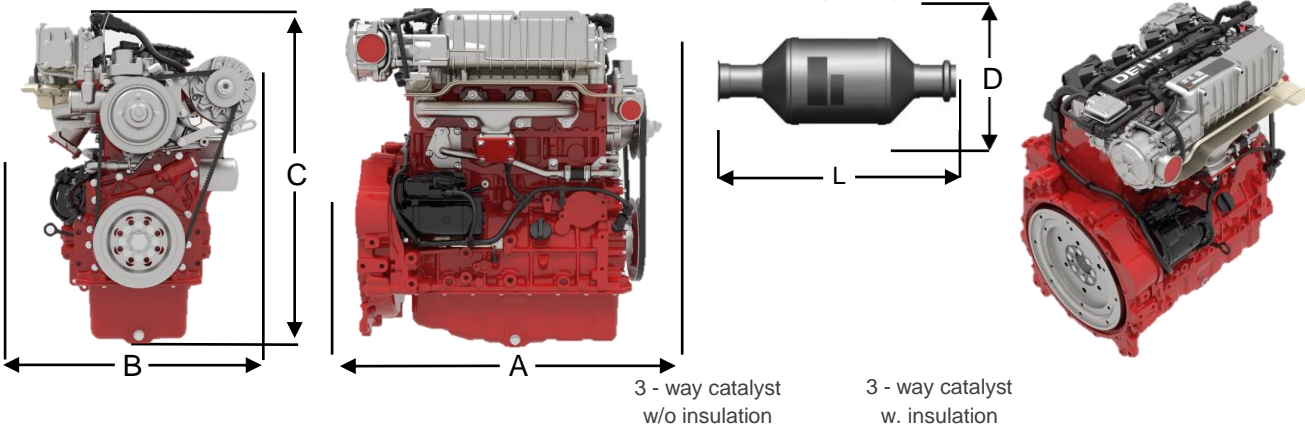

ENGINE TYPE		A	B	C	D	L	D	L	3 - way catalyst
G 2.2	mm	576	647	747	136	362	159	362	● ■
G 2.9	mm	678	572	734	136	400	159	400	● ■

- Standard for US Tier 2
- Standard for EU Stage V



**DEUTZ AG**  
 Ottostraße 1  
 51149 Cologne  
 Germany  
[www.deutz.com](http://www.deutz.com)  
[www.sdeutz.com](http://www.sdeutz.com)